

# Cartridge Heating / Cooling Meter PolluCom C Installation and Operation Instructions



Our compact meter PolluCom C is used for measuring energy consumption in plants carrying water as heating or cooling liquid.

These installation and operation instructions specify how to install and operate our compact meter PolluCom C and its variants. The instructions are an essential part of the supplied items and must be handed over to the final user.

## Supplied items

- PolluCom C measuring cartridge
- 1 O-ring seal (put on the bottom part of the measuring cartridge)
- 1 profile washer
- sealing material (2 or 3 selflock seals, sealing wire)
- additionally for variants with removable integrator: 1 wall adapter, 2 screws, 2 dowels, 1 self-adhesive foil
- these installation and operating instructions  
Content

## Contents

1. Technical data .....	1
2. Important directions .....	1
3. Required tools and materials .....	2
4. Installing the meter .....	2
5. Installing the separate temperature sensor .....	3
5.1 Direct installation in heating or cooling liquid .....	3
5.2 Installation in well .....	3
6. Display options .....	3
6.1 User menu .....	4
6.2 Target day menu .....	5
6.3 Archive menu .....	5
6.4. Service menu .....	5
6.5 Control menu for tariff purposes .....	6
6.6 Parameter menu .....	6
7. Functional test, sealing .....	7
8. Possible error situations .....	7
9. Optical interface and optional modules .....	7
9.1 Optical interface .....	7
9.2 M-Bus option according to EN 13757-3 .....	8
9.3 Mini-Bus option .....	8
9.4 Remote read-out option for heat consumption pulses .....	8
9.5 M-Bus option / Mini-Bus option with two contact inputs .....	8
9.6 Optional integrated data logger .....	8

## 1. Technical data

Meter size	q <sub>p</sub> 0.6	q <sub>p</sub> 1.5	q <sub>p</sub> 2.5
Nominal flow rate q <sub>p</sub> in m <sup>3</sup> /h	0.6	1.5	2.5
Minimum flow rate q <sub>i</sub> in m <sup>3</sup> /h	0.006	0.015	0.025
Accuracy class	3 resp. 2 acc. to EN 1434		
Ratio q <sub>i</sub> /q <sub>p</sub>	1:100		
Maximum flow rate q <sub>s</sub> in m <sup>3</sup> /h (short-term)	1.2	3	5
Starting flow rate in m <sup>3</sup> /h (average value)	0.0015	0.0025	0.003
Temperature measuring range	5 ... 150 °C (-20 ... 150 °C for water-antifreezer-liquids, not sealed)		
Temperature difference range	3 ... 100 K		
Cut-off threshold	0.15 K		
Measuring cycles	Temperatures: 2 sec Flow rate and power: 4 sec Energy and volume: 16 sec		
Allowable temperature in the flow sensor	5 ... 90 °C (short peaks of 110 °C)		
Flow rate at 0.1 bar pressure loss in m <sup>3</sup> /h	0.5	1.2	1.7
Pressure loss at q <sub>p</sub> in bar	0,15	0,17	0,21
k <sub>vs</sub> value (flow rate at 1 bar pressure loss in m <sup>3</sup> /h)	1.53	3.65	5.45
Allowable working pressure in bar	16		
Connection thread	M 60 X 2		
Length of connection cable of split meters	Ca. 0,3 m		
Allowable ambient temperature	5 ... 55 °C		
Environmental class	C acc. to EN 1434		
Protection class	IP 54		
Battery lifetime for PolluCom C, CX, C/S, CX/S	6 years + 1 year reserve (Calibration period in Germany)		
Battery lifetime for PolluCom C/S 10, CX/S 10	10 years (special version for markets not subject to calibration periods)		

## 2. Important directions



Applied standard: EN 1434, parts 1, 3 and 6 and VDE 0100

- Heating and cooling meters are measuring instruments, which have to be handled with utmost care. In order to protect them against damage and soiling only remove their package immediately they will be installed. The meter must not be carried by the cable. For cleaning purposes use nothing else but a cloth moistened with water.
- If more than one heat meter are to be used in the same billing unit, choose the same meter types and fitting positions in order to achieve the fairest possible billing of heat consumption.
- Take care that PolluCom C, well or ball valve are perfectly installed, because otherwise there might be the danger of being scalded

by leaking heating liquid. For the same reason close the stop cocks first of all before removal.

- Subject to manufacturing conditions the brass connection threads might be sharp-edged. Therefore we recommend wearing protection gloves.
- The meter contains a lithium battery. This battery must not be opened by force, be short-circuited or exposed to water or temperatures exceeding 80°C. Empty batteries, electronic instruments or components are special refuse and have to be disposed of at suitable collection centers.

### 3. Required tools and materials

- Hooked wrench (PolluCom C measuring cartridge)
- Fork wrench SW 22 (By-pass cap of the manifold EAS)
- Fork wrench SW 24 (bulb well)
- Screw driver slot 0,8x5 (bulb well)
- Diagonal cutting pliers (sealing wire)
- Fat for screw thread

### 4. Installing the meter

Our PolluCom C can be used as a heat meter as well as a chill meter. Therefore the following terms are used in the text hereinafter:

Return pipe of heating plants: **colder pipe**  
Supply pipe of heating plants: **warmer pipe**

Return pipe of cooling plants: **warmer pipe**  
Supply pipe of cooling plants: **colder pipe**

Install our PolluCom C in the colder pipe. For installation in the warmer pipe the version PolluCom CX is available.

Cooling plants – due to possible condensation – require the versions PolluCom C/S oder CX/S, which are equipped with removable integrator. Remove the integrator from the flow sensor (pulling upwards) and mount it at a suitable place by means of the supplied wall adapter.

Some of our PolluCom C can also be used as a combined heat/chill meter (PolluCom C/S H and CX/S H), depending on the version. In this case the integrator must also be mounted separately. Switching over between heat and chill metering can be controlled according to chapter 6.5, the switch-over point can be changed by means of the service software MiniCom 3.

The integrator of our PolluCom C can be turned through approx. 330 degrees to a perceptible stop. Forced further turning causes the damage of internal parts and the expiry of warranty claims

The flow direction of the heating or cooling liquid is shown by an arrow on the flow sensor. Additional straight pipes before or behind the meter are not required.

The flow sensor and both temperature sensors are to be installed within the same circuit of the heating or cooling plant. Our PolluCom C can be installed in horizontal position, horizontal position but inclined through max. 90 degrees, or in vertical position.

Before the flow sensor (or at another suitable point in the heating or cooling plant) a dirt trap is to be installed, as well as a stop cock before and behind the flow sensor, in order to be able to remove the meter after expiry of the verification period without being compelled to empty the pipeline.

Before installing the meter, rinse the pipeline thoroughly, remove the fitting piece (included in the standard mounting kit) and then mount the meter using new gaskets.

#### Examples of installation:

1. Check the installation point for completeness. An installed original PolluCom C manifold (EAS) and the original PolluCom C bulb well should have been installed. Only then can the PolluCom C measuring cartridge be installed. Attention: In chilling plants the supply pipe is the colder and the return pipe is the warmer line. (Please pay attention to the introductory explanations of this chapter about this subject)

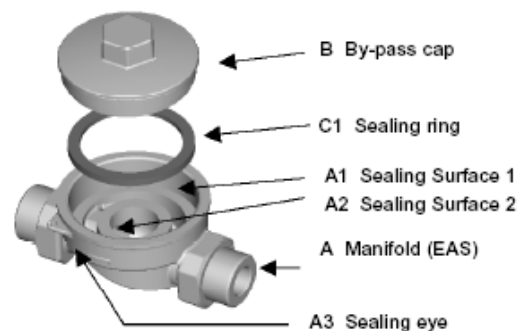

Fig. 1 Manifold

2. Turn off heating / chilling and its circulating pump respectively.
3. Close the shut-off valves before and after the manifold (EAS).
4. Check the installation site again for correct flow direction (arrow on the manifold), if necessary correct the installation of the manifold EAS.
5. Unscrew the by-pass cap (B) from the manifold (A), remove the profile seal (C) from the manifold EAS and clean the two sealing surfaces of the manifold EAS (A1 and A2).

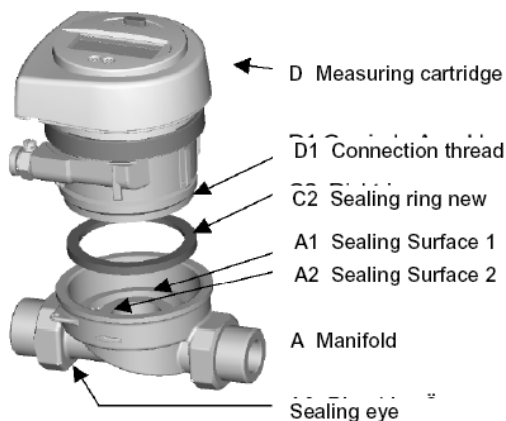

Fig.2 Installation PolluCom C measuring cartridge

6. Remove the protection cap from the connection thread (D1) of the PolluCom C measuring cartridge (D) and put the delivered new profile seal (C2) on the sealing surfaces (A1 and A2). Under no circumstances use any other sealings!
7. Screw the measuring cartridge (D) into the manifold EAS and tighten it to the limit stop. For this purpose use a hooked wrench only!
8. Seal the measuring cartridge together with the manifold by pulling the enclosed sealing wire in one piece through the sealing eyes of the measuring cartridge (D2) and the manifold EAS (A3), tighten it and secure it with the enclosed selflock seal.

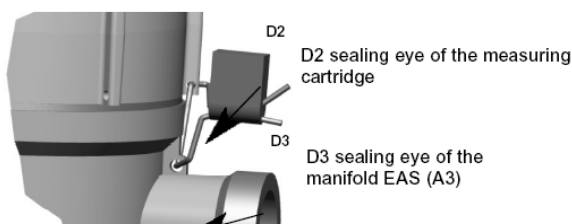

Fig. 3: Sealing example

9. Install and seal the temperature sensor according to chapter 5.
10. Then open shut-off valves and check the complete installation site for leakage.
11. Afterwards put heating / chilling again into operation.

## 5. Installing the separate temperature sensor

Standard cable length of the separate temperature sensor is approx. 1.5 m. If possible, lay the cable in a cable conduit or a cable pipe. In order to achieve the most accurate temperature measurement possible, the tip of the temperature

sensor is to be positioned in the middle of the pipe diameter.

Laying the cables keep a minimum distance of 0.3 m from to electromagnetic disturbers and cables carrying  $\geq 220$  V.

### 5.1 Direct installation in heating or cooling liquid

For this type of installation you can use Sensus ball valves (order no. 68502314 G 1/2" or 68502315 G 3/4") for instance. The ball valve is also used for shutting off the pipeline so that the temperature sensors can be removed without draining the pipe.

### 5.2 Installation in well

Insert the temperature sensor as far as possible into the well and secure it against dropping out by using the holding screw. Then lay the supplied sealing wire into the groove around the hexagon head, feed it through the borehole of the holding screw and seal with the supplied selflock seal.

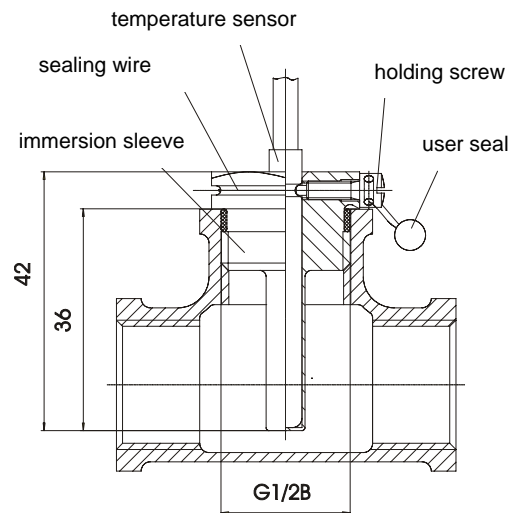

Fig. 4: Installation in bulb well

## 6. Display options

The various display options of our PolluCom C are divided up into six menus. Depending on the version of the supplied meter and the display masking respectively, some of the display items marked with an asterisk (\*) may be shielded. If required, the masking can be changed by means of the service software MiniCom 3 via the meter's optical interface. In normal condition the display switches on in intervals of 4 seconds and shows the accumulated heat consumption for one second. Depress the red key in order to activate the first display item of the user menu

(accumulated heat consumption). Select the other five menus by depressing the red key for 8 seconds. The display shows the selection menu L1 to L6.

	User menu
	Target day menu *
	Archive menu *
	Service menu
	Control menu for tariff purposes *
	Parameter menu *

fig. 4: selection of display menus

The above menus can sequentially be selected by shortly depressing the red key. As soon as the required menu is displayed depress the red key for 2 seconds in order to come to this menu. Each one of the separate display items of the menu is called up one after the other by shortly depressing the key. If the key is not operated for 4 minutes, the display returns by itself to the normal condition.

In all menus a blinking impeller symbol (left bottom display corner) shows that volume pulses are received. The shown value figures are to be considered exemplarily.

### 6.1 User menu

	Error message (only in case of error)		Primary M-Bus address (preset in factory to: 0) *
	Accumulated heat and/or chill energy		Secondary M-Bus address (preset in factory to: meter serial number) *

	Target day consumption incl. corresponding date *
	Accumulated volume *
	Segment test
	Tariff consumption 1 * (if activated)
	Tariff consumption chill * (if activated)
	Consumption pulse meter1* (optional)
	Consumption pulse meter2* (optional)
	Instantaneous flow *
	Instantaneous energy *
	Temperature in warmer pipe *
	Temperature in colder pipe *
	Temperature difference *
	Customer's reference number *

# Cartridge Heating / Cooling Meter PolluCom C Installation and Operation Instructions



## 6.2 Target day menu

All display items are marked with an arrow symbol. Display of all stored consumption values on an adjustable annual target day.

	Target day consumption for heat and/or chill energy *
	Target day consumption for volume *
	Target day consumption for tariff 1 (if activated) *
	Target day for tariff chill (if activated) *
	Target day consumption for pulse meter 1 (optional) *
	Target day consumption for pulse meter 2 (optional) *
	Return to selection menu (depress for 2 seconds) *

## 6.3 Archive menu

All display items are marked with a calendar sheet symbol. Starting from the current date, the consumption on the turns of the past 16 months is displayed (six-figure date in the format dd.mm.yy below the main display).

Moreover the maxima for flow and efficiency are displayed for the current month (incl. date and time), here the word „today“ appears below the main display.



















	Select the required month, beginning with "today", by short keystroke, then depress key for 2 seconds *
	Heat and/or chill energy *

	Volume *
	Tariff consumption 1 (if activated) *
	Tariff consumption chill (if activated) *
	Consumption pulse meter 1 (optional) *
	Consumption pulse meter 2 (optional) *
	Maximum flow in selected month incl. date (average) *
	Maximum flow in selected month incl. time (average) *
	Maximum efficiency in selected month incl. date (average) *
	Maximum efficiency in selected month incl. time (average) *
	Hours of error condition *
	Return to month selection (depress for 2 seconds) *

## 6.4. Service menu

Each display item is marked with a man symbol. The service menu shows maximum values and settings.









	Absolute maximum flow incl. date (average) *
	Absolute maximum flow incl. time (average) *
	Absolute maximum efficiency incl. date (average) *

  34863 kW 08h59	Absolute maximum efficiency incl. time (average) *
  893 3006.10	Absolute maximum temperature in warmer pipe incl. date *
  528 3006.10	Absolute maximum temperature in colder pipe incl. date *
 28-07-10 DATE	Current date *
 09h48 TIME	Current time *
 31-07-10 +	Next target day *
 d 35	Operating days *
 2996 BAtt	Battery voltage * (calculated)
 h 68 ▲	Accumulated failure hours *
 2 PrAdr	Primary M-Bus address (preset in factory to: 0) *
 03840275 SECAdr	Secondary M-Bus address (preset in factory to: meter serial number) *
 ALL AMr	Data communication mode (length and structure of M-Bus protocol) *
 V 28	Version of firmware
 CRC 33FE	Check sum
 00003948 Wh	High-resolution energy display *
 00007340 L	High-resolution volume *

 rEturN	Return to selection menu (depress for 2 seconds) *
--	--

## 6.5 Control menu for tariff purposes

Each display item is marked with the letters „CTRL“. Here the tariff functions can be set and controlled.

 in 15 Ctrl	Set averaging interval for flow and energy *
 14823 kW Ctrl	Efficiency in current averaging interval *
 1253 m/h Ctrl	Flow in current averaging interval *
 5 09h48 Ctrl	Set tariff 1 start time (if activated) *
 E 19h46 Ctrl	Set tariff 1 finish time (if activated) *
 PC 250 * Ctrl	Switch-over temperature for chill metering (if activated) *
 A 0.750 * Ctrl	Switch-over point for negative temperature difference chill metering (if activated) *
 CF 0000 Ctrl	Corrective factor for water-antifreezer-mixtures *
 rEturN Ctrl	Return to selection menu (depress for 2 seconds) *

## 6.6 Parameter menu

Each display item is marked with the tool symbol. This menu is protected by password. The password corresponds to the **last three digits** of the eight-digit serial number on the meter body. At first "000" appears. Then depress the key for approx. 2 seconds, and the left cipher starts blinking. Change the value of the blinking digit by holding the key continuously depressed. Release the key as soon as the required value is shown. A short keystroke confirms the set value and switches to the next digit. Here repeat the same procedure. As soon as the last digit has been set, the menu will be released.

# Cartridge Heating / Cooling Meter PolluCom C Installation and Operation Instructions



Now the required items can be selected by short keystroke, setting the values analogously to entering the password.

	Password enquiry *
	Set primary M-Bus address *
	Set secondary M-Bus address *
	Set customer's reference number *
	Set averaging interval for flow and efficiency *
	Set data communication mode (One, One Plus, All) *
	Pulse valency of the first external meter (0,25 to 10.000 L/Imp.) *
	Pulse valency of the second external meter (0,25 to 10.000 L/Imp.) *
	Set date *
	Set time *
	Set target day *
	Reset absolute maxima *
	Reset failure hours *
	Return to selection menu (depress for 2 seconds) *

## 7. Functional test, sealing

Open the stop cocks and test the installed units for leaks.

For checking purposes, the current values of flow, energy as well as supply and return flow temperature can be called to the display according to chapter 6.1.

In order to protect the meter against tampering, the supplied self-lock seals have to be applied to the following points:

- union of the flow sensor
- insertion point of the separately installed temperature sensor (see also chapter 5)

## 8. Possible error situations

Our PolluCom C is equipped with an automatic self-checking function. In case of error the display shows a four-digit error code in the format „Err XYZW“, which can be decoded as follows:

- X:** maintaining a check on the temperature sensors  
**Y:** maintaining a check on the integrator  
**Z:** error statistics  
**W:** error in flow sensor

Extract:

Code	Decoding
Err 1010	Temperature sensors exchanged by mistake or return flow temperature exceeds supply flow temperature
Err 2010	One or both temperature sensors is/are short-circuited
Err 4010	Cable failure of return pipe temperature sensor
Err 8010	Cable failure of supply pipe temperature sensor
Err 0084	Error in impeller scanning

The error situation „Err 1010“ is usually caused by temporary plant conditions with the temperature in the warmer pipe falling by 3 K or more below the temperature in the colder pipe.

In case of all other error situations please contact our Technical Service Center.

## 9. Optical interface and optional modules

### 9.1 Optical interface

All meters are equipped with an optical interface. Via an optical data coupler (e.g. order no. 04410230 for RS 232 port or order no. 184023 for USB port) set parameters can be changed with the help of the parameter software MiniCom 3, or the meter can be read out via the readout system DOKOM Mobil. The data interface is

activated by a short keystroke for one hour. By every meantime data communication this period of time starts again, so that e.g. a logger readout at 15-minute or hourly intervals is possible over a longer period of time.

## 9.2 M-Bus option according to EN 13757-3

This option allows the meter to be read out via its primary or secondary address by means of a M-Bus level converter (300 and 2400 Baud, automatic recognition). Both addresses can be set in the parameter menu (see chapter 6.6) or with the help of the Service software MiniCom 3 (note: secondary address preset in factory in accordance with the serial number on the meter body). The primary address can be set between 0 and 250 and is preset in factory to 0)

The optional two-wire cable is integrated at a suitable place in the M-Bus system. Polarity of the two wires can be disregarded.

## 9.3 Mini-Bus option

This option is suitable to connect the meter with an inductive reading point (MiniPad). The total length of the two-wire cable between meter and reading point must not exceed 50 meters. Polarity of the two wires can be disregarded. The transferred protocol corresponds to the M-Bus protocol, and the meter can be read out via MiniReader or by means of the read-out system DOKOM Mobil.

## 9.4 Remote read-out option for heat consumption pulses

Pulse valency: 1 kWh  
Closing time: 125 ms  
Bounce time: none  
Max. voltage: 28 V DC or AC  
Max. current: 0.1 A

Connect the two-wire cable to a suitable pulse totalizer or to a contact input of a house control system. Polarity of both wires can be disregarded.

## 9.5 M-Bus option / Mini-Bus option with two contact inputs

In addition to the module specified in chapter 9.2 and 9.3 resp., two external consumption meters (cold water, warm water, electricity, gas, others) with passive remote read-out contact can be connected (Reed switch or open collector).

This option has two connection cables altogether (1 x two wires, 1 x four wires). The two-wire cable (white and brown wire) is integrated at a suitable place in the M-Bus or MiniBus system, polarity can be disregarded.

Connect the four-wire cable as follows:

white = external meter 1 / positive pole  
brown = external meter 1 / negative pole  
green = external meter 2 / positive pole  
yellow = external meter 2 / negative pole

Specification of contact inputs

Required closing time: > 125 ms  
Input frequency: ≤ 3 Hz  
Terminal voltage: 3 V

Both contact inputs preset in the factory to:

*input 1:* cold water meter, pulse valency 10 litres, initial meter reading 0.00 m<sup>3</sup>

*input 2:* warm water meter, pulse valency 10 litres, initial meter reading: 0.00 m<sup>3</sup>

Other values can be set via the service software MiniCom 3.

## 9.6 Optional integrated data logger

The integrated data logger stores consumption values and current values (efficiency, flow, temperatures) in a selectable time interval (1 to 1440 minutes, capacity: 1260 data sets). The logger data can be read out via optical interface, M-Bus or Mini-Bus by means of the service software MiniCom 3. The time interval (preset in factory to 60 minutes) can also be changed by means of MiniCom 3.

Material number: 28504975

Edition: 004-1009  
Subject to changes

Sensus GmbH Ludwigshafen  
Industriestraße 16  
D-67063 Ludwigshafen

Phone: + 49 (0) 621 6904-1113  
Fax: + 49 (0) 621 6904-1409  
E-Mail: info.de@sensus.com

