

# 420

## Multijet meter Wet dial - Class B or C HRI AMR interface



### Main characteristics

#### DN 15 to 40 PN 16

Excellent legibility of the register

AMR compatible with HRI systems providing a pulse weight from 1 litre

Possible meter marking customizing (serial number, bar code, customer logo)

Strong protection against tampering

Robust, suited to extended periods of immersion

Compatible with WVG body standard

### Application

As with all meters in the Sensus Metering Systems portfolio, the 420 multijet meter benefits from our long experience in the manufacture of high-performance meters.

The 420 reliability, resistance to bad water quality and quiet operation will satisfy both end users and network managers.

The new oversized identification plate offers a solution to show in a legible way all the meter characteristics and provides the possibility for a customized bar code or logo.

Old multi-jet, wet dial meters can be retrofitted with 420 meters by qualified repair shops with the use of special upgrade kits.

Through its standard HRI interface the 420 can be used in any network where a reliable and versatile AMR system is required.

The HRI solution is retrofittable and can be added any time after the meter has been installed.

### Available options

Connectors

Non return valve

HRI electronic sensor (Data Unit, Pulse Unit, Sensus((S))cout)

## Accuracy

The balanced force and upward movement of the water in the injection box means that the starting flow rate is low.

The direct transmission gives the 420 a good sensitivity, especially at low flow rates.

## Reliability

The 420 meter has high protection against corrosion, water hammer, pressure and heat due to the use of high quality copper alloy and thick polycarbonate glass.

The internal components, made of high-grade polymers, have been designed to preserve the initial performance of the meter:

- The turbine is supported by sapphire which prevents shaft wear
- The double filtration provided by the pipe strainer and the seat screen prevents foreign particles passing through the mechanism.

## Register

The 5-drum display has large digits (5mm height) with black marking on white drums. Therefore the meter can be read from a distance of over one metre. Pointers on the meter dial indicate sub-multiples of m<sup>3</sup>.

There is no risk of condensation with the wet dial. This is protected by a very thick polymer glass designed to withstand the pressure and environment changes during all meter life.

## Tampering protection

Through its design, the 420 offers extremely high protection against tampering to avoid any misuse of the meter:

- As the meter has no magnetic transmission and a magnet free HRI interface, it is totally unaffected by a magnet placed near the meter
- The use of a robust brass body combined with a thick (8mm) polycarbonate glass prohibit any mechanical mechanism stopping

## Typical Accuracy Curve

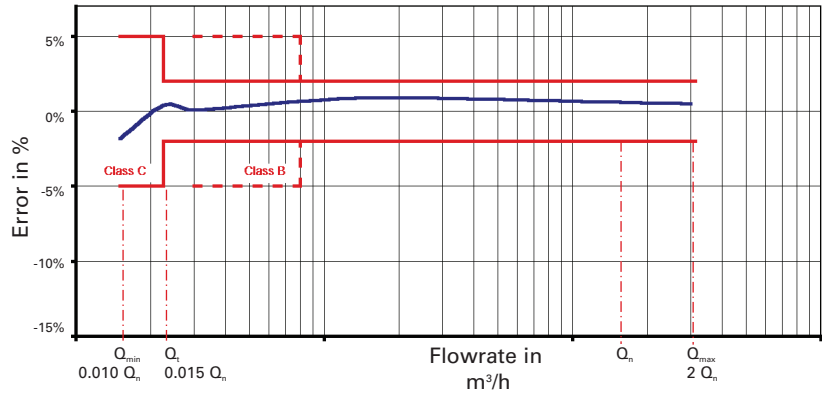

## Typical Pressure Loss Curve

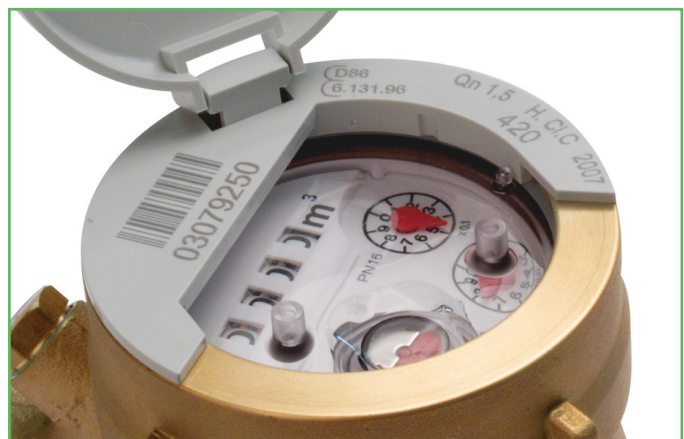
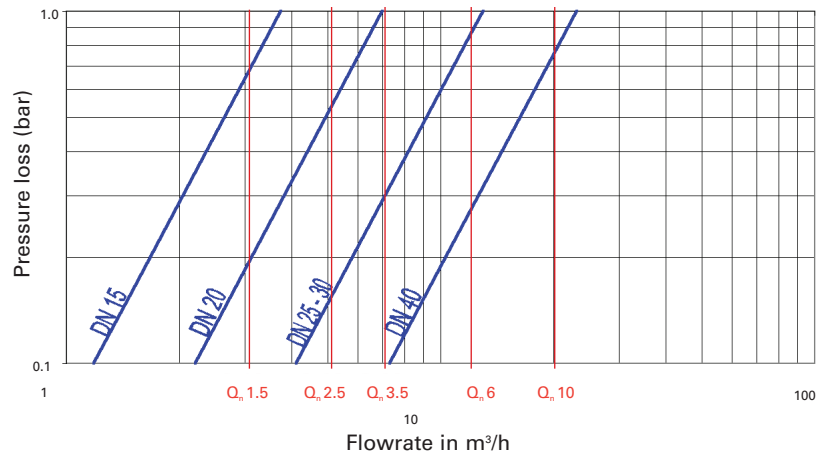

## Compliance

The 420 meter complies with:

- ISO 4064,
- Recommendation n°49 of the OIML,
- EC directive 75/33.

## Approvals

The 420 meter is approved to the EEC pattern approval in horizontal position:

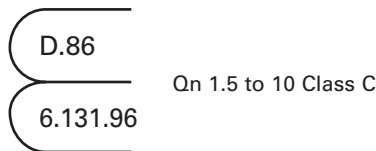

On request, the 420 meter can be delivered with a class B seal.

## Marking

Two arrows on the body indicate the flow direction.

The nominal flowrate, the metrological class, the EC pattern approval number and the year of manufacture are engraved in a highly legible way on an oversized identification plate on top of the meter.

The manufacturer's name and the type of the meter are printed on the dial.

The meter can be customized on request with specific serial number, bar code or logo.

## Installation and Maintenance Instructions

The 420 meter must be installed in a low point of the pipeline.

The meter must be installed with the arrow cast on the body corresponding to the direction of water flow.

Before fitting the water meter, all pipe work must be flushed out to remove all foreign bodies.

An upstream valve is recommended to allow installation and removal of the meter. When connecting the meter with the water network, the upstream valve must be opened slowly in order to fill the meter with water smoothly.

During tightening, the meter can be maintained in position with a standard tool owing to the flats on the pipe.

No special maintenance is required.

## Performance Data

### Metrological Characteristics - EEC Directive 75/33

Nominal size	DN (Qn)	mm	15	20	25	30	40
Nominal flowrate	Qn	m <sup>3</sup> /h	1.5	2.5	3.5	6	10
Metrological class			C				
Maximum flowrate	Qmax	m <sup>3</sup> /h	3.0	5.0	7.0	12.0	20.0
Minimum flowrate (tolerance ±5%)	Qmin	l/h	15.0	25.0	35	60	100
Transitional flowrate (tolerance ±2%)	Qt	l/h	22.5	37.5	53	90	150

### Operational Characteristics

Nominal Size	DN (Qn)	mm	15	20	25	30	40
Starting flowrate		l/h	5	8	15	12	20
Minimum flowrate		l/h	12	15	23	30	35
Transitional flowrate		l/h	15	20	30	45	55
Maximum registration		m <sup>3</sup>	10 <sub>s</sub>				
Lowest resolution		litre	0.05				
Pressure loss at Qmax		bar	0.55	0.51	1.00	0.85	0.75
Pressure class	PN	bar	16				

## Dimensions and Weights

### Dimensional characteristics

Nominal Size	DN (Qn)	mm	15	20	25	30	40
Length	L	mm	165 <sup>(1)</sup>	190 <sup>(2)</sup>	260	260	300
Width	D	mm	96	96	103	103	134
Total height	H	mm	120	120	135	135	152
Total height with assembled HRI			150	150	165	165	182
Height to pipe axis	h	mm	34	36.5	45	45	61
Piping dimension		inch	1/2"	3/4"	1"	1" 1/4	1" 1/2
Tail piece	Diameter	inch	3/4"	1"	1" 1/4	1" 1/2	2"
thread	Pitch	mm	26.44	33.25	41.91	47.80	59.61
Weight		kg	1.814	2.309	2.309	2.309	2.309
			1.4	1.6	2.3	2.5	5.0

<sup>(1)</sup> also available in length 145 & 170 mm <sup>(2)</sup> also available in length 165

## Dimensional diagram

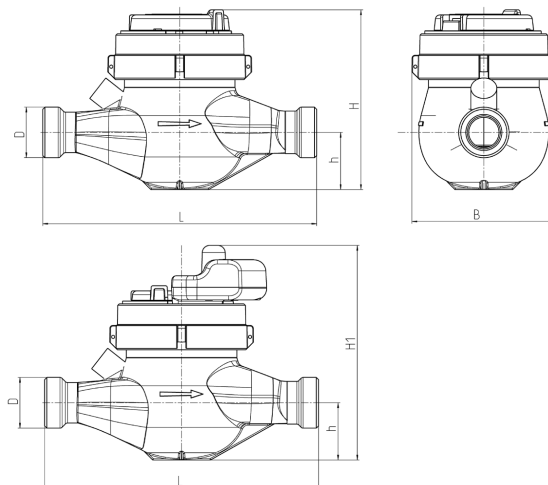

## HRI Options

The dial of the 420 meter is equipped as standard with a pointer able to activate the HRI sensor. The HRI reproduces the mechanical register index exactly, by detecting the direction of rotation of the pointer. It provides a reliable pulse- and data interface for remote and mobile readout. The HRI can be fitted in the field on already installed Sentinel water meters or ordered factory fitted to the meter.

For more information refer to the leaflets LS 8100 and LS 3300

The HRI is available as three versions:

### 1. HRI Pulse Unit (A-version)

The litre pointer activates the HRI allowing a basic resolution of one litre per pulse. The output pulse value can be factory set using the divisor D (e.g. D = 100 means 1 pulse per 100 litres).

The possible pulse output D values are (amongst others):

1 / 10 / 100 / 1000 / 2.5 / 25 / 250

### 2. HRI Data Unit (B-version)

The design of the HRI Data Unit integrates a data interface to read the meter index and identification number. This version additionally provides a pulse output as described above.

The HRI Data Unit can be connected to a M-Bus network for remote read or a MiniPad for mobile inductive read (MiniBus), both in accordance with the IEC 870 or Sensus protocol.

### 3. Sensus((S))cout-S Radio Unit

Integrated Sensus((S))cout radio with the usage of long term proven and reliable HRI sensing technology. Radio read is made via the handheld Psion WA pro and Dokom mobile (WinCE) software

For any additional information about the HRI, please refer to the data sheets LS 8100 and LS 3300.



**qualityaustria**  
Succeed with Quality

Certified according to ISO 9001  
Quality Management System Quality Austria Reg.no. 3496/0

#### UK & Ireland Enquiries

Sensus UK Systems Ltd, International House, Southampton International Business Park,  
George Curl Way, Southampton SO18 2RZ UK  
T: +44 (0) 1794 526100 F: +44 (0) 1794 526101 Email: [info.gb@sensus.com](mailto:info.gb@sensus.com) [www.sensus.com](http://www.sensus.com)

#### International Enquiries

Sensus GmbH Ludwigshafen, Industriestrasse 16, 67063 Ludwigshafen Germany  
T: +49 (0) 621-6904-0 F: +49 (0) 621-6904-1409 Email: [info.int@sensus.com](mailto:info.int@sensus.com) [www.sensus.com](http://www.sensus.com)